

Model - J3M0683W9-SDB 115kWe IMOIII Exempt

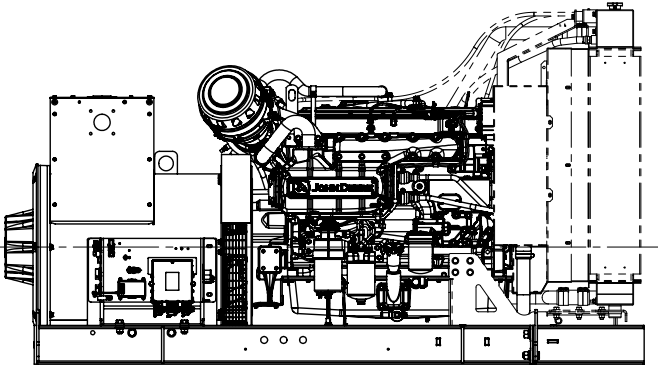

Overall Dimensions

98.8" L
41.0"W
55.8"H

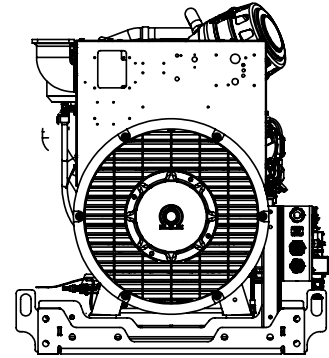

Standard Spec Configuration

Engine

- John Deere 6068AFM85 173HP @1800rpm
- HPCR and GenII Electronics
- EPA Tier III Compliant, IMO3 Exempt
- Controls Inc M3-4004 Panel
- Radiator Cooled, Diesel Radiator
- Blower Fan
- Full Belt Guard
- CCV System
- K&N Air Cleaner
- 4-point lift lugs
- Oil Pan Drain Valve
- Fuel Return Restriction Alarm
- 24v DC Engine electrical System
- ABS Type Approved

Generator

- Marathon Mariner
- 115kWe PMG, Drip Cover, Heater, DVR
- 12 wire

Optional Spec Configuration

- Keel Cooled, Dry Exhaust
- Heat Exchanger Cooled, Wet Exhaust
- 12v DC Engine Electrics
- ABS Certified
- SOLAS
- Various AC Voltage Configurations
- Various Control Panel Options and Harness Lengths
- Various service and filter locations



ENGINE PERFORMANCE CURVE

Rating: **60 Hz - 173hp (129kW) @ 1800 RPM**
 Application: **Marine**

PowerTech™ 6.8L Engine
Model: 6068AFM85

Generator Efficiency (%)	Power Factor	Calculated Gen-Set Rating		Prime Power	10% Overload Power
		kW	kVA	hp (kW)	hp (kW)
88-92	0.8	114-119	143-149	173(129)	190(142)

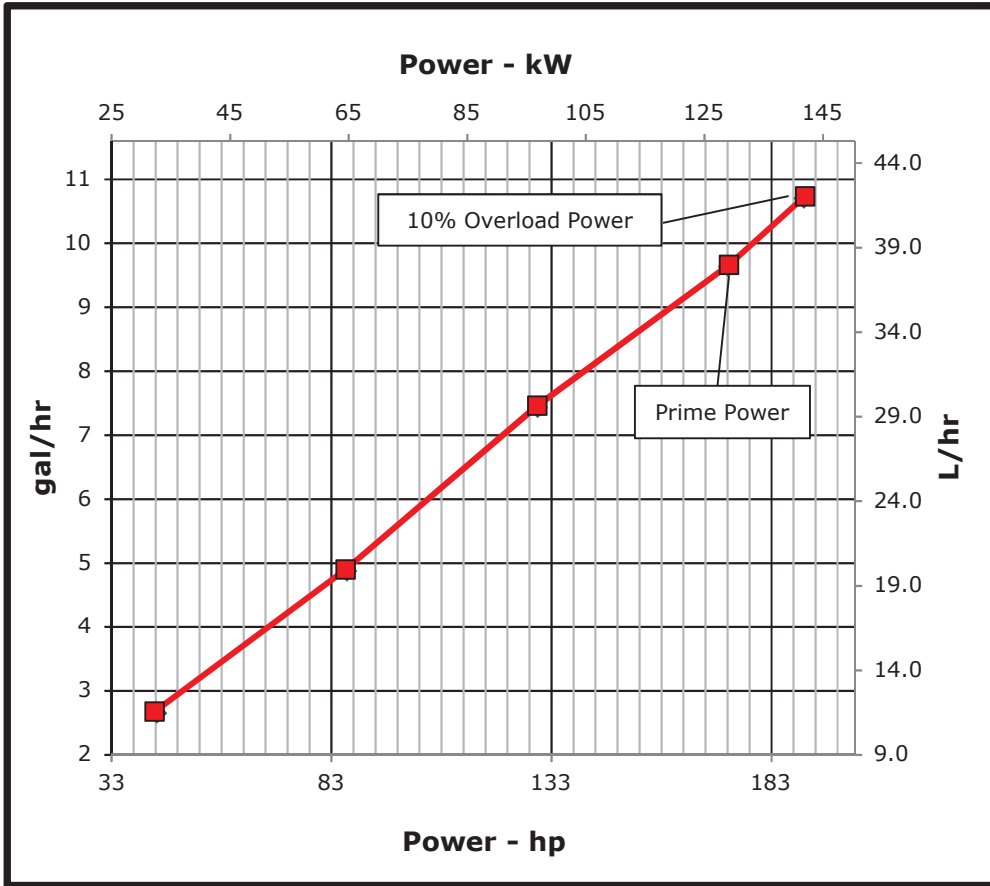

REFERENCE CONDITIONS

Air Intake Restriction.....12 in.H₂O (3 kPa)
 Exhaust Back Pressure..... 30 in.H₂O (7.5 kPa)

Rated speed and power
 Gross power guaranteed within ±5% at ISO 8665/SAE J1228 and ISO 3046/SAE J1995
 Test conditions:

77 °F (25 °C) air inlet temperature
 29.31 in.Hg (99 kPa) barometric pressure
 104 °F (40 °C) fuel inlet temperature
 0.853 fuel specific gravity @ 60 °F (15.5 °C)

Ambient air temperature is defined to be the temperature of ambient air close to operating vessel that is not influenced in any manner by operating characteristics of the vessel (free field temp).

Conversion factors: Power: kW = hp x 0.746
 Fuel: 1 gal = 7.1 lb, 1 L = 0.85 kg
 Torque: N·m = lb-ft x 1.356

All values from currently available data. Subject to manufacturing and measurement variations and to change without notice.
 Actual performance is subject to application and operation conditions outside of John Deere control.

All pressures shown in gauge pressure

Notes:

Marine Generator: The Marine generator engine rating is the power available under normal varying electrical load factors for an unlimited number of hours per year in commercial applications. This rating incorporates a 10% overload capability, and conforms to ISO 8528 prime power. Average load over a 24-hour period shall not exceed 67% of the prime rating, of which no more than 2 hours are between 100% and 110% of the prime rating.

Constant speed engines are not certified for constant speed propulsion applications (i.e. variable pitch propeller, hybrid propulsion system).

Designed/Calibrated to meet:

- EPA Marine Tier 3 Constant Speed Auxiliary (40 CFR 1042)
- IMO MARPOL Annex VI Exempt (<130 kW)

Certified by:

Ref: Engine Emission Label

29-Jun-20

Performance Curve: 6068AFM85_H

All values at rated speed, power, and standard conditions, per SAE J1995 unless otherwise noted.

Engine Installation Criteria

General Data

Model	6068AFM85		
Number of Cylinders	6		
Bore	107 mm	4.21 in	
Stroke	127 mm	5.00 in	
Displacement	6.8 L	415 in ³	
Compression Ratio	16.7:1		
Valves per Cylinder, Intake/Exhaust	2/2		
Combustion System	Direct Injection		
Firing Order	1-5-3-6-2-4		
Engine Type	In line, 4 Cycle		
Aspiration	Turbocharged and Aftercooled		
Aftercooling System	Engine Coolant		
Engine Crankcase Vent System	Closed		

Cooling System*

Engine Coolant Heat Rejection**	168 kW	9580 BTU/min	
Max. Pressure Drop Across KC and Piping	40 kPa	6 psi	
Coolant Flow	197 L/min	52.0 gal/min	
Min. Coolant Pump Inlet Pressure	30.3 kPa	4.4 psi	
Thermostat Start to Open	71 °C	160 °F	
Thermostat Fully Open	83 °C	182 °F	
Engine Coolant Capacity, HE	34 L	9.0 gal	
Engine Coolant Capacity, KC	33.5 L	8.8 gal	
Min. Coolant Fill Rate	12 L/min	3.2 gal/min	
Min. Pressure Cap	110.3 kPa	16 psi	
Min. Pump Inlet Pressure	30 kPa	4.4 psi	
Max. External Coolant Restriction	40 kPa	5.8 psi	
Normal Operation Max Top Tank Temperature	100 °C	212 °F	
≤ 5% of Total Operating Time Top Tank Temperature	100-110 °C	212-230 °F	
Absolute Max Top Tank Temperature	110 °C	230 °F	
Recommended Fuel Cooler	3 kW	146 BTU/min	
Engine Radiated Heat	10 kW	543 BTU/min	

* The cooling system should be capable of typical at ambient up to the maximum conditions in which the vessel will operate.

Typical operation is defined as the average load sustainable in the vessel over 10 min.

** Reference 32 °C Sea Water Temperature

Physical Data

Length to rear face of block	1034 mm	40.7 in
Length to rear face of flywheel housing (SAE #2)	1172 mm	46.1 in
Length maximum	1374 mm	54.1 in
Width maximum	862 mm	33.9 in
Height, crank centerline to top	644 mm	25.4 in
Height, crank centerline to bottom	291 mm	11.5 in
Weight, with oil, no coolant (includes engine, flywheel housing, flywheel, and electronics)	787 kg	1735 lb
Center of Gravity Location, X-axis From Rear Face of Block	390 mm	15.4 in
Center of Gravity Location, Y-axis Right of Crankshaft	-14 mm	-0.6 in
Center of Gravity Location, Z-axis Above Crankshaft	186 mm	7.32 in
Max. Allowable Static Bending Moment At Rear Face of Flywheel Housing (for installations up to 5-G)	814 Nm	600 lb-ft
Thrust Bearing Load Limit, Forward Continuous	2.2 kN	495 lbf
Thrust Bearing Load Limit, Forward Intermittent	4 kN	899 lbf
Thrust Bearing Load Limit, Rearward Continuous	1 kN	225 lbf
Thrust Bearing Load Limit, Rearward Intermittent	2 kN	450 lbf

Electrical System

Min. Recommended Battery Capacity, 12V @32 °F (0 °C)	925 amps
Min. Recommended Battery Capacity, 24V @32 °F (0 °C)	625 amps
Starter Rolling Current, 12V @32 °F (0 °C)	920 amps
Starter Rolling Current, 24V @32 °F (0 °C)	600 amps
Min. Voltage at ECU during Cranking, 12V	6 volts
Min. Voltage at ECU during Cranking, 24V	10 volts
Max. Allowable Start Circuit Resistance, 12V	0.002 ohms
Max. Allowable Start Circuit Resistance, 24V	0.0012 ohms
Electrical Component Maximum Temperature Limit	125 °C 257 °F
Maximum ECU Temperature	105 °C 221 °F

Performance Curve: 6068AFM85_H

All values at rated speed and power at standard conditions per SAE J1995 unless otherwise noted.

Engine Installation Criteria

Fuel System

ECU Description	L14		
Fuel Injection Pump	HPCR		
Governor Type	Electronic		
Volumetric Fuel Consumption, Prime	38 L/hr	10.0 gal/hr	
Mass Fuel Consumption, Prime	32.3 kg/hr	71 lb/hr	
Total Fuel Volumetric Flow	162 L/hr	42.8 gal/hr	
Total Fuel Mass Flow	138 kg/hr	304 lb/hr	
Max. Fuel Inlet Restriction*	20 kPa	80 in.H2O	
Max. Fuel Inlet Pressure	20 kPa	80 in.H2O	
Max Fuel Return Pressure	20 kPa	80 in.H2O	
Normal Operation Fuel Temperature	40 °C	104 °F	
Max. Fuel Inlet Temperature	100 °C	212 °F	
Min. Recommended Fuel Line Inside Diameter	6.85 mm	0.27 in	
Min. Recommended Fuel Line Size	5 (-) AN		
Primary Fuel Filter	10 mic		
Secondary Fuel Filter	2 mic		

Lubrication System

Oil Pressure at 1800 RPM**	328 kPa	48 psi	
Max. Crankcase Pressure	2 kPa	8 in.H2O	
Maximum Installed Angle, Front Down	0 deg		
Maximum Installed Angle, Front Up	12 deg		
Engine Angularity Limits Any Direction, Continuous***	25 deg		
Engine Angularity Limits Any Direction, Intermittent***	35 deg		

Seawater Pump System

Seawater Pump Flow	192 L/min	51 gal/min	
Max. Suction Lift	3 m	9.8 ft	
Max. Outlet Pressure	140 kPa	20 psi	
Max. Inlet Restriction	30 kPa	4 psi	

* With clean filters

** With John Deere Plus-50 II™ 15w-40, not applicable with break in oil.

*** With 19BP option

Air Intake System

Engine Air Flow	14.4 m ³ /min	510 ft ³ /min	
Intake Manifold Pressure	198 kPa	28.7 psi	
Manifold Air Temperature	88 °C	191 °F	
Maximum Manifold Air Temperature	130 °C	266 °F	
Max. Allowable Temperature Rise, Ambient Air to Engine Inlet	17 °C	30 °F	
Max. Air Intake Restriction, Clean Air Cleaner	3 kPa	12 in.H2O	
Max. Air Intake Restriction, Dirty Air Cleaner	6.25 kPa	25 in.H2O	
Min. Ventilation Area	0.0888 m ²	138 in ²	

Performance Data

Prime Power	129 kW	173 hp	
10% Overload Power	142 kW	190 hp	
Rated Speed	1800	RPM	
Low Idle Speed	1000	RPM	
Prime Torque	685 Nm	505 lb-ft	
BMEP, Prime	1266 kPa	184 psi	
Rated Pferdestärke, Prime (metric hp)	176	ps	
Front Drive Capacity, Intermittent	907 Nm	669 lb-ft	
Front Drive Capacity, Continuous	907 Nm	669 lb-ft	
Friction Power @ Rated Speed	18.7 kW	25.06 hp	

Exhaust System

Exhaust Flow	29.3 m ³ /min	1036 ft ³ /min	
Exhaust Flow @ gas STP	14.7 m ³ /min	518 ft ³ /min	
Exhaust Temperature	368 °C	694 °F	
Max. Allowable Exhaust Restriction	7.5 kPa	30 in.H2O	
Max. Shear on Turbocharger Exhaust Outlet	11 kg	24.3 lb	
Max. Bending Moment on Turbocharger Exhaust Outlet	7 Nm	15.4 lb-ft	
Min. Exhaust Pipe Diameter, Dry	101.6 mm	4.0 in	
Min. Exhaust Pipe Diameter, Wet	127.0 mm	5.0 in	

Performance Curve: 6068AFM85_H

All values at rated speed and power at standard conditions per SAE J1995 unless otherwise noted.

Engine Installation Criteria

Engine Performance Data Table

Engine Power	Crank Power		Crank Torque		Fuel Consumption		BSFC
	kW	hp	Nm	lb-ft	L/hr	gal/hr	
25%	32	43	171	126	11.6	3.1	305
50%	64	86	342	252	20.0	5.3	263
75%	97	130	514	379	29.6	7.8	260
100%	129	173	685	505	38.0	10.0	250
110%	142	190	753	555	42.0	11.1	252

Performance Curve: 6068AFM85_H

All values at rated speed and power at standard conditions per SAE J1995 unless otherwise noted.

ECR #	REV	DESCRIPTION OF CHANGE	DATE	REV BY
	-	INITIAL RELEASE		

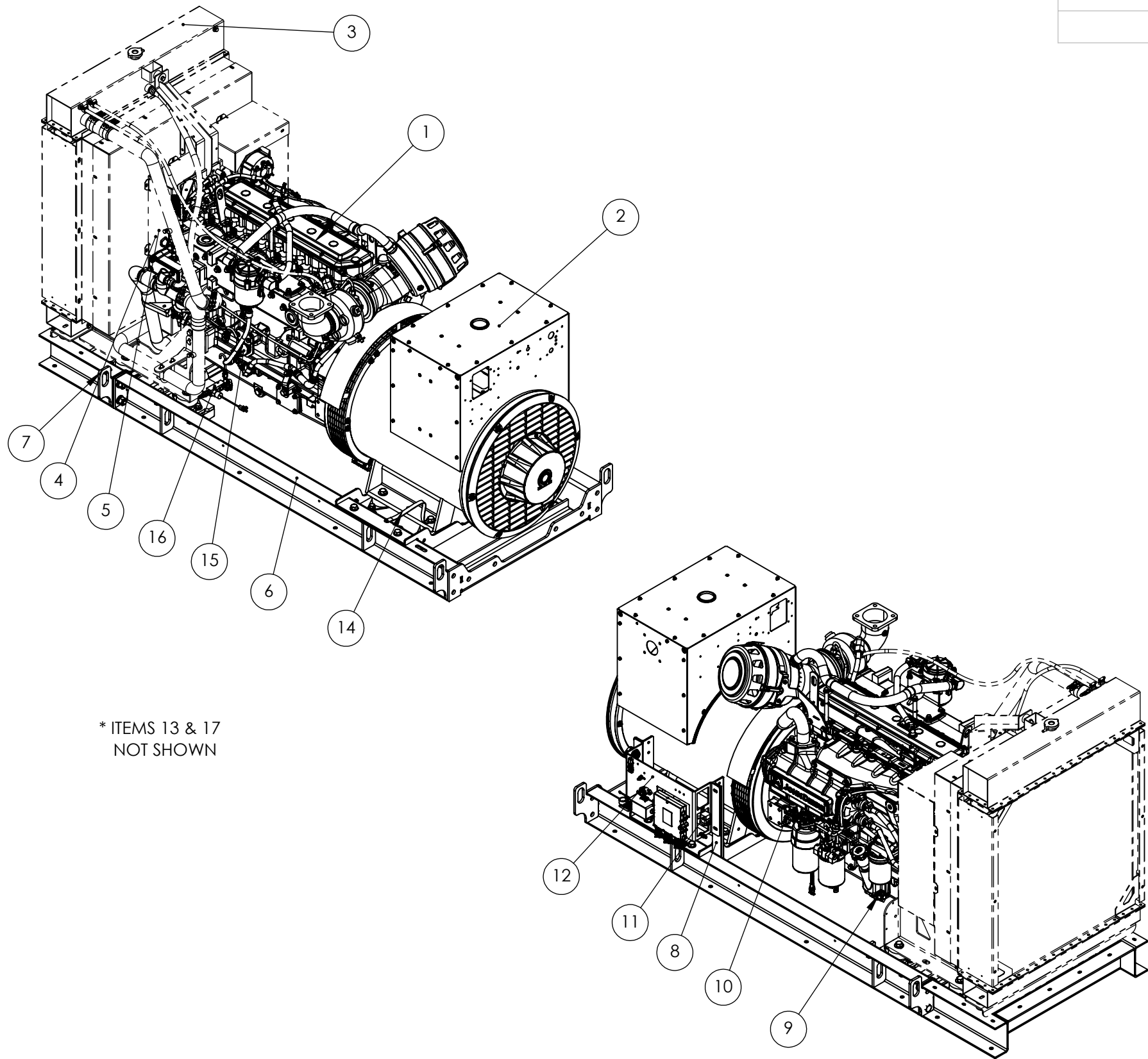

* ITEMS 13 & 17
NOT SHOWN

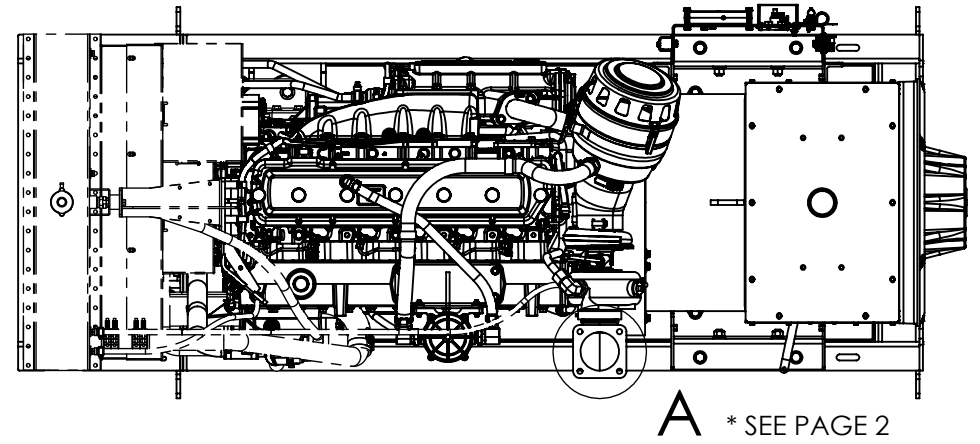

A * SEE PAGE 2

*REMOVABLE LIFT EYE
NOTE: FAN POWER DRAW ROUGHLY 6kW

ITEM #	PART NUMBER	DESCRIPTION	QTY.
1	68AM32-173-GK00 68AM34-173-GH00	6068AFM85, 12V, KC, 173HP 6068AFM85, 24V, KC, 173HP	1
2	431PSL62523PDHD	125kWe, PMG, DRIP COVER, HEATER, DVR	1
3	300-A3572	DR4558 RAD W/LEGS & PLUMBING	1
4	300-A3638	31" DIA, BLOWER, 4" SPACER	1
5	300-A3620	13.3" / .82:1 FAN DRIVE	1
6	250-A3639	6068 W/RAD SKIDBASE W/PAN	1
7	*250-07256	LIFTING LUG, BOLT-ON	4
8	250-07225	GEN II ECU BRACKET	2
9	RE509019	OIL DRAIN VALVE	1
10	3J982-6-8	FUEL INLET BARB	1
11	RE52665 RE505214	12V FUEL / KICKBACK RELAY 24V FUEL / KICKBACK RELAY	1
12	DZ110509	GEN II ENGINE TO ECU HARNESS KIT, 10FT	1
13	700-07240	5' GEN II GENERATOR HARNESS	1
14	69925K34	GROUNDING BRAID	1
15	700-A3843	START RELAY WIRING	1
16	150-A2906	FUEL RETURN ALARM KIT	1
17	BELL690	PIN & CONNECTOR KIT	1

RHINELANDER, WI (715) 365-0500
SEVILLE, OH (330) 769-1850
ESSEX, CT (860) 767-7502

VALUE-ADDED ENGINE & DRIVETRAIN DISTRIBUTORS

CONFIDENTIALITY NOTICE:

ALL RIGHTS TO MANUFACTURE, COPY, REPRODUCE, OR DISPERSE THIS DRAWING OR THE INFORMATION CONTAINED HEREIN ARE RESERVED UNLESS OTHERWISE SPECIFIED IN WRITING BY SUPERIOR DIESEL, INC OR BELL POWER SYSTEMS, LLC.

TOLERANCE ON DIMENSIONS UNLESS OTHERWISE NOTED	DRAWN KDP	DATE	TITLE 115kWe, 12V OR 24V RAD, 6068AFM85, SKID MARINE GENSET
ANGLES: ±.5°	CHECKED KDP	DATE	
FRACTIONS: ±1/32	MODELS AFM85		DRAWING NO J3M0683W9-SDB
DECIMALS: .0 = ±.060 .00 = ±.030 .000 = ±.010	MATERIAL	WEIGHT ±3875 LBS	SHEET 1 OF 2
			REV. -

PLEASE REVIEW, VERIFY, SIGN AND DATE THIS DESIGN TO ENSURE THAT OUR DESIGN MEETS YOUR APPLICATION REQUIREMENTS. PLEASE RETURN TO YOUR SDI/BPS REPRESENTATIVE.

BY: _____ DATE: _____

- NOTES:**
1. INSTALLATION DRAWING ONLY.
 2. DO NOT SCALE FROM DRAWING.
 3. CONTACT SUPERIOR DIESEL FOR ALL ENGINE CODES AND PART NUMBERS.

ECR #	REV	DESCRIPTION OF CHANGE	DATE	REV BY
	-	INITIAL RELEASE		

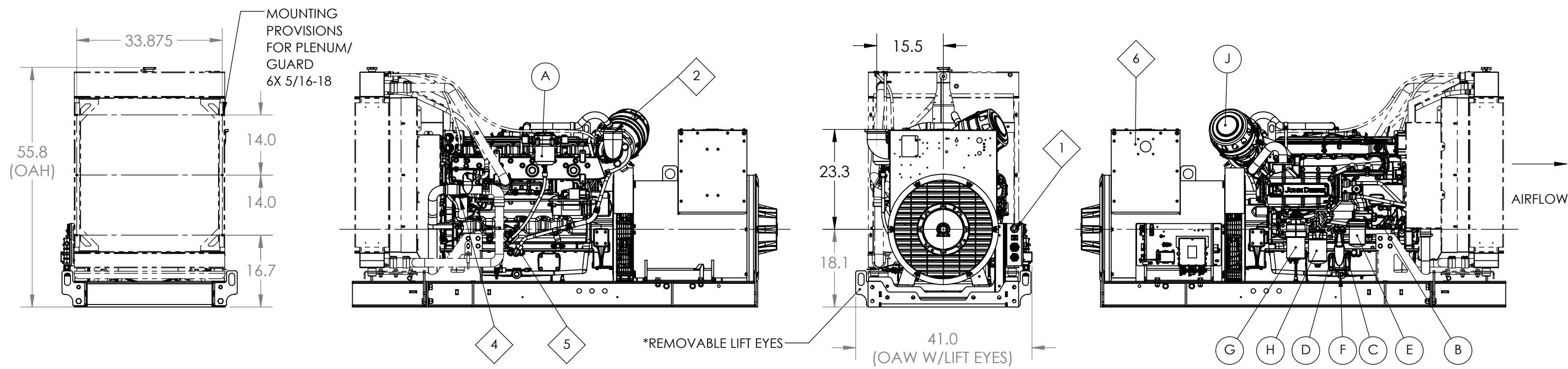

CUSTOMER SERVICE POINTS ●

ITEM	NAME
A	CCV SYSTEM
B	COOLANT DRAIN(S)
C	OIL FILL(S)
D	OIL DIPSTICK
E	OIL FILTER
F	OIL DRAIN
G	PRIMARY FUEL FILTER
H	SECONDARY FUEL FILTER
I	COOLANT FILL & PRESSURE CAP
J	WASHABLE AIR FILTER

CUSTOMER INSTALLATION POINTS ◆

ITEM	NAME	REMARKS
1	ECU HARNESS CONNECTION	C04, C05, C18, C20
2	DRY ELBOW	SEE DETAIL A
3	FUEL INLET	1/2" BARB
4	FUEL RETURN	1/8-27 NPTF
5	START RELAY	SEE OPTION DRAWING
6	GENERATOR	MARATHON 431PSL

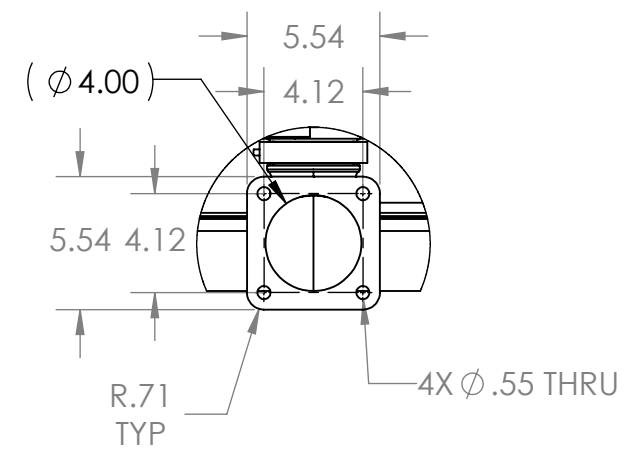
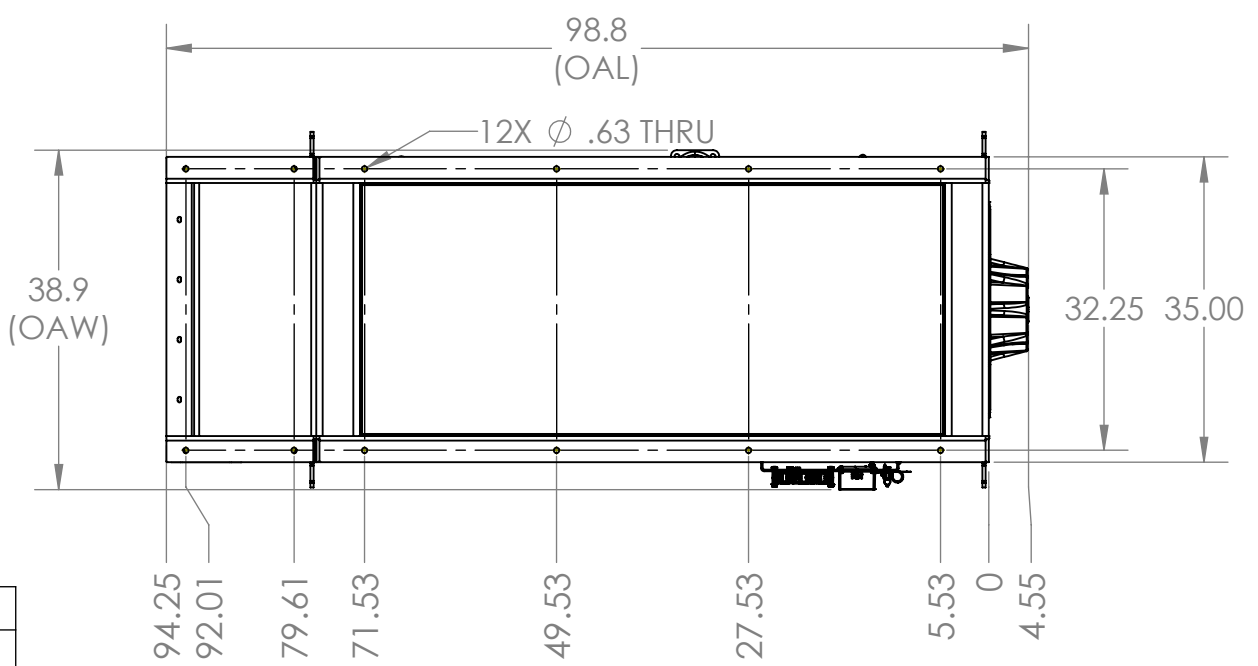

DETAIL A
DRY EXHAUST FLANGE
SCALE 1 : 8

CONFIDENTIALITY NOTICE:

ALL RIGHTS TO MANUFACTURE, COPY, REPRODUCE, OR DISPERSE THIS DRAWING OR THE INFORMATION CONTAINED HEREIN ARE RESERVED UNLESS OTHERWISE SPECIFIED IN WRITING BY SUPERIOR DIESEL, INC OR BELL POWER SYSTEMS, LLC.

RHINELANDER, WI (715) 365-0500
SEVILLE, OH (330) 769-1850
ESSEX, CT (860) 767-7502

VALUE-ADDED ENGINE & DRIVETRAIN DISTRIBUTORS

TOLERANCE ON DIMENSIONS UNLESS OTHERWISE NOTED	DRAWN KDP	DATE	TITLE 115kWe, 12V OR 24V RAD, 6068AFM85, SKID MARINE GENSET
ANGLES: ±.5°	CHECKED KDP	DATE	
FRACTIONS: ±1/32	MODELS AFM85		DRAWING NO J3M0683W9-SDB
DECIMALS: .0 = ±.060 .00 = ±.030 .000 = ±.010	MATERIAL	WEIGHT ± 3875 LBS	SHEET 2 OF 2
			REV. -

- NOTES:**
- SEE APPLICABLE ENGINE INSTALLATION DRAWINGS FOR FURTHER INFORMATION.
 - ORIGIN - CENTERLINE OF CRANKSHAFT AT REAR FACE OF BLOCK.