

# Mini Excavators XE27U



XCMG FOR YOUR SUCCESS

Rated Power: 15.4 kW (20.7 hp)  
Operating Weight: 2 780 kg (6,129 lb)  
Operating Weight with canopy: 2 680 kg (5,908 lb)  
Standard Bucket Capacity: 0.06 m<sup>3</sup> (0.08 yd<sup>3</sup>)

**XCMG NORTH AMERICA CORPORATION**  
Add: 5145 Schirlls St. Las Vegas, Nevada 89118  
Tel: +1 725 605 2777  
Fax: +1 725 605 2888  
E-Mail: bin@xcmg.com

**XUZHOU CONSTRUCTION MACHINERY GROUP IMP. & EXP. CO., LTD**  
Add: NO.1, Tuolanshan Road, Xuzhou Economic Developing Zone,  
Jiangsu, China 221004  
Tel: +(86) 516 8773 9285  
E-Mail: bin@xcmg.com



[www.xcmg.com](http://www.xcmg.com)



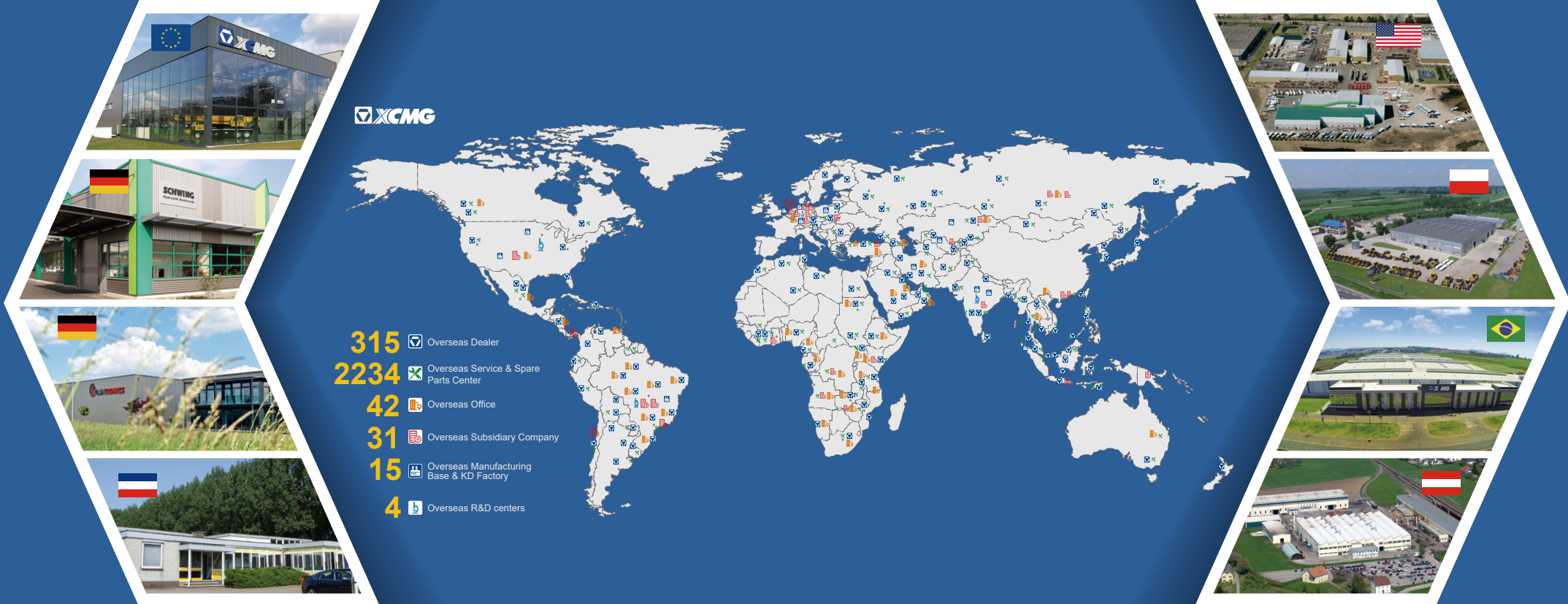

# INTRODUCTION OF XCMG

Founded in 1943, XCMG is the largest enterprise in the Chinese construction machinery industry. We offer the most diverse product line and the highest technological standards. We provide a comprehensive set of construction solutions, and we are the most internationally competitive firm in the industry. On KHL Yellow Table, we rank No. 1 in China and No.3 globally.

Across our offices in China, the US, Germany, India, and Brazil, XCMG has established a global collaborative research platform including national-level R&D facilities focused on advanced smart manufacturing technology. Our R&D team consists of top talents from around the globe. They are researching cutting-edge technologies such as new energy, unmanned driving and high-end parts. Our work has earned us numerous international patents and awards.

XCMG has the most comprehensive product line, meaning we can offer fully comprehensive solutions in 9 areas: hoisting, earthwork, road building & maintenance, mining, concrete & paving, tunnel-building & underground construction, high-altitude firefighting equipment & special-purpose vehicles, railway & bridge construction, sanitation engineering. All these solutions can be customized to suit our customers' needs.

At XCMG, our five-continent sales network gives our products worldwide visibility. We have 300 overseas distributors, over 10 overseas manufacturing bases and KD (Knockdown) factories, and products in more than 180 countries and regions. We supply our global customers with pre-sales, mid-sales and after-sales service, and a convenient, efficient one-stop financing and leasing service. XCMG's total annual exports and overseas income consistently come top of the industry in China.

We care deeply for the welfare of the people. We support numerous charitable causes, and are quick to the scene during disaster relief efforts.

XCMG is all set to become an eternal brand with our feet on the ground and eyes on the horizon. XCMG's ambition leads us forever forwards. XCMG is scaling its Everest, and is determined to reach the top.

## The XE27U comes with every feature you expect from a mini excavator in its tonnage.

Variable angle boom, 75° to the left and 55° to the right, reduced swing tail, and standard rubber track give you an edge when undertaking operations in confined sites such indoors, basement, garden, and community landscapes.

Powered by a reliable 20.7 hp Kubota engine, you can count on it to finish tough jobs in various operating conditions. When it comes to efficiency, versatility is a critical factor. That's why the machine is compatible to multiple attachments that can be installed within a short period of time with its manual quick coupler. You will finish the operations with ease and comfort in the jobsite.





# Compact Machine with Excellent Performance

## A Superior Model with Considerate Design

Developed with the concept of “Safe, Reliable, Efficient and Comfortable”, the XE27U hydraulic excavator offers additional value to the operator. New features are presented making the machines more productive, versatile, and cost effective.

- Kubota T4F engine D1105, along with our load-sensing hydraulic system provides efficiency and fuel economy.
- This compact short-tail excavator is designed to perform a wide variety of tasks on the most challenging jobsites such as in demolition, landscaping, earthmoving or material handling. It gets the job done as you expected!
- Grouped service points are within reach from the ground, making maintenance easier and reducing your potential downtime.



### — Angle Boom

The left (75°) and right (55°) boom swing angles give the operator confidence and efficiency during complex operating conditions like parallel wall digging or travelling in narrow spaces.

### — Made for Easy Transportation

With a set of buckets, hammer and rubber track, the XE27U weighs less than 6 200 lb. And the accessible large tow rings make it easy to switch between your jobsites.

### — AUX1&2 and Coupler Pipelines

With the multiple programmable 2-way proportional auxiliary lines and quick-coupler piping the XE27U meets almost all your attachment needs.

### — Boom, Arm Safety Valves and Standard Blade Holding Valve

The XE27U is equipped with standard boom cylinder safety valve, arm cylinder valve and a dozer holding valve to protect the operator as well as individuals around during operations.

# Operator Comfort

## Large Operator Environment with Ergonomic Control Layout

The XE27U gives the operator a large comfortable space in which to work. The ergonomic control layout, travel levers with pedals and adjustable arm rests are engineered to reduce operator fatigue and increase productivity. The cab offers sound insulated working environment with radio, stereos, suspension seat. Standard electric proportional joysticks with roller control can handle your attachments such as thumb as fine as you expected. The 7" color LCD display conforms to ergonomics and can switch to the attachment mode quickly. There are 8 languages set in system for users to select. Many automatic control functions, like intelligent fault diagnosis, maintenance information prompt, and fuel filling prompt, are set, effectively shortening the maintenance time.

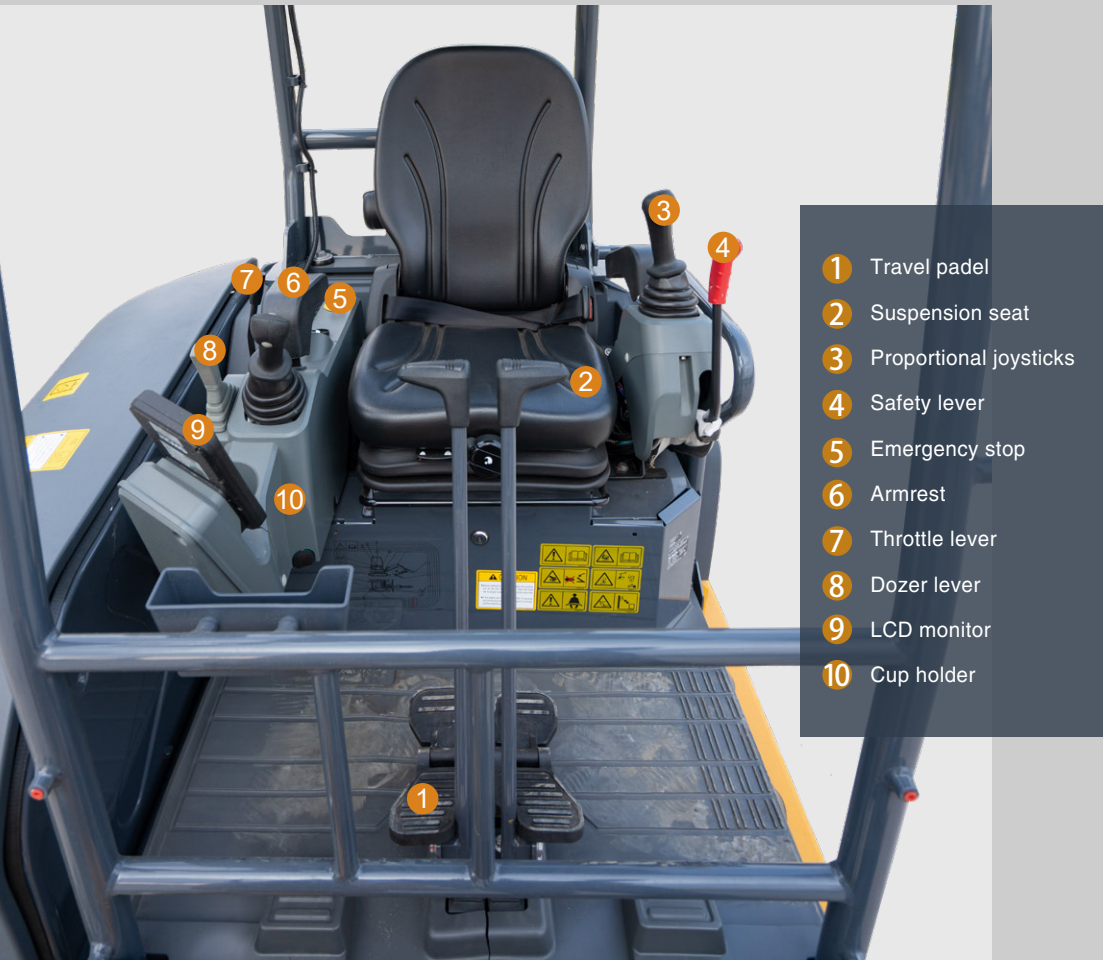

# Excellent Visibility

## › The Canopy Guarantees Superior Visibility

The four post canopy provides the operator with clear view and easy entrance and exit on the condition that safety and comfort are guaranteed. When operating in indoors and confined areas, great visibility can increase productivity. Features such as electric proportional joysticks with roller control, LCD display, arm rest, cup holder have also been equipped for the canopy version.



## One-sided Engine Maintenance

The XE27U is designed for lower maintenance cost with longer service intervals - resulting in more machine availability on-site. Meanwhile, skilled XCMG-trained technicians are available to provide extra support when needed.



# Safety Features

## ► Easy Service Access

XE27U is developed with taking particular attention to ease of service access. With a single access point for the daily maintenance of all main components, fuel level gauge and refuelling through the lockable cap.



## ► Centralized Lubrication System

The swing motor, slewing bearing, angle boom cylinder are equipped with centralized lubricating technology. And self-lubricating bearings are utilized in the boom and arm to reduce daily maintenance time and further increase machine uptime.

## ► To Protect the Machine and Operating Sites

The routes of hydraulic pipelines and hoses are well-organized and the arm cylinder is guarded and the front light is integrated under the boom to avoid impacts and damages from rocks and other debris during operations. The over heat warning can remind the operator when necessary to better protect the engine. And the continuous rubber tracks can minimized damage made to the paved operating sites. And the ignition socket is covered to withstand rain and dust.



## ► To Protect the Operator and People Around

Rotation warning beacon with buzzer, right hand side emergency stop, lock lever, rear mirrors on both sides, battery disconnect switch, and top lights make sure both the operator and people around the machine can be well-protected.





# Technical Specifications

## Engine

### XE27U

Make/model	Kubota/D1105 /Tier 4F
Fuel/cooling	Diesel/Liquid,forced circulation
No. of cylinders	3
Piston displacement	1 123 cm <sup>3</sup> (68.5 in <sup>3</sup> )
Power output	15.4 kW (20.7 hp) / 2400 rpm (20.7 hp/2400 rpm) (ISO 14396)
Max torque	70.3 N·m/1600 rpm (51.9 ft.lb/1600 rpm)
Bore x stroke	78.0x78.4 mm (3.1 in.x3.1 in.)
Alternator	12 V-40 A

## Hydraulic system

This original XCMG design allows independent and combined operations of all functions by hydraulic pilot controlled levers.

### > Pump

### XE27U

Type	Load-sensing axial-piston pump with variable displacement
Total hydraulic capacity	82.8 L/min (21.9 gal/min)
AUX1 & AUX2 maximum flow rate	25 L/min (6.6 gal/min)
AUX1/AUX2 standard relief pressure	180/180 bar (2,610.7/2,610.7 psi)

### > Maximum system pressure

### XE27U

Boom	243 bar (3,524.4 psi)
Arm / bucket / travel	243/243/243 bar (3,524.4/3,524.4/3,524.4 psi)
Swing	162 bar (2,349.6 psi)

## Digging forces (ISO 6015)

### XE27U

Digging force, long Arm (ISO 6015)	14 kN (3,147.3 lbf)
Digging force, bucket (ISO 6015)	23 kN (5,170.6 lbf)

## Undercarriage

X-type undercarriage. The heavy-duty crawler chassis is very resilient with its fully welded, stressfree structure. Long service life is ensured by the use of first-class materials: hydraulic chain adjusters with shock-absorbing return springs, lifetime-lubricated track rollers and idlers.

### > Number of rollers and track shoes

### XE27U

Bottom rollers (per side)	3
Track shoes	Rubber
Overall track length	1 980 mm (6'6")
Shoe width	300 mm (12")

## Fluid capacities

### XE27U

Cooling system (radiator capacity)	6.5 L (1.7 gal)
Engine lubrication plus oil filter	5.1 L (1.4 gal)
Fuel tank	33 L (8.7 gal)
Hydraulic tank	22 L (5.8 gal)
Hydraulic system	40 L (10.6 gal)

## Environment

Noise levels comply with environmental regulations (dynamic values).

### > Noise emission

### XE27U

Noise level LpA (ISO 6396)	79 dB(A)
Noise level LwA (ISO 6395)	93 dB(A)

## Swing mechanism

High-torque, axial piston motor with planetary reduction gear bathed in oil. Swing circle is single-row, shear type ball bearing with induction-hardened internal gear. Internal gear and pinion gear immersed in lubricant. Equipped with an automatic multi-disc slew brake.

### > Swing system

### XE27U

Boom swing, left	75°
Boom swing, right	55°
Swing speed	10 rpm

## Drive

Each track is driven by an independent, high-torque, axial piston motor through planetary reduction gears. Two control levers provide smooth travel or counterrotation upon demand.

### > Speed & traction

### XE27U

Travel speed (low - high)	2.1-3.1 km/h (1.2-1.9 mph)
Traction force	29.7 kN (6,676.8 lbf)
Gradeability	30°

## Weight

### XE27U

Operating Weight with cab	2.78 t (6,129 lb)
Operating Weight with canopy	2.68 t (5,908 lb)
Ground pressure with cab	26.4 kPa (3.8 psi)
Ground pressure with canopy	25.5 kPa (3.7 psi)
Transport mass (no attachment)	2 650 Kg (5,842.2 lb)
Weight of steel tracks	200 Kg (440.9 lb)
Weight of rubber tracks	134.5 Kg (296.5 lb)



# Lifting Capacities

## XE27U

With cab standard arm(1 300 mm/4'3") without bucket

Lift Point Height	Over front blade up/down					Over Side					Max Radius (mm/ft)
	Lift At Max Radius (Kg/lb)	1 m/3'3"	2 m/6'7"	3 m/9'10"	4.0 m/13'1"	Lift At Max Radius (Kg/lb)	1 m/3'3"	2 m/6'7"	3 m/9'10"	4.0 m/13'1"	
3 m/9'10"	402/886.3			*435/959		290/639.3			360/793.7		3 373/11'1"
2 m/6'7"	310/683.4			*479/1,056		220/485			350/771.6		3 928/12'11"
1 m/3'3"	282/621.7		847/1,867.3	455/1,003	294/648.2	198/436.5		525/1,157.4	321/707.7	207/456.4	4 105/13'6"
Ground	290/639.3		791/1,743.9	430/948		203/447.5		525/1,157.4	298/657		3 969/13'
-1 m/-3'3"	350/771.6	*1 229/2,709.5	794/1,750.5	425/937		244/537.9	*1 229/2,709.5	527/1,161.8	294/648.2		3 471/11'5"
-2 m/-6'7"	*475/1,047.2		*596/1,314			465/1,025.2		562/1,239			2 275/7'6"

With canopy standard arm(1 300 mm/4'3") without bucket

Lift Point Height	Over front blade up/down					Over Side					Max Radius (mm/ft)
	Lift At Max Radius (Kg/lb)	1 m/3'3"	2 m/6'7"	3 m/9'10"	4.0 m/13'1"	Lift At Max Radius (Kg/lb)	1 m/3'3"	2 m/6'7"	3 m/9'10"	4.0 m/13'1"	
3 m/9'10"	386/851			*435/959		278/613			346/763		3 373/11'1"
2 m/6'7"	296/653			466/1,027		210/463			336/741		3 928/12'11"
1 m/3'3"	269/593		811/1,788	435/959	281/619	189/417		551/1,215	307/677	197/434	4 105/13'6"
Ground	277/611		756/1,667	410/904		193/425		501/1,105	284/626		3 969/13'
-1 m/-3'3"	334/736	*1 229/2,710	758/1,671	406/895		232/511	*1229/2,709.5	503/1,109	280/617		3 471/11'5"
-2 m/-6'7"	*475/1,047		*596/1,314			445/981		538/1,186			2 275/7'6"

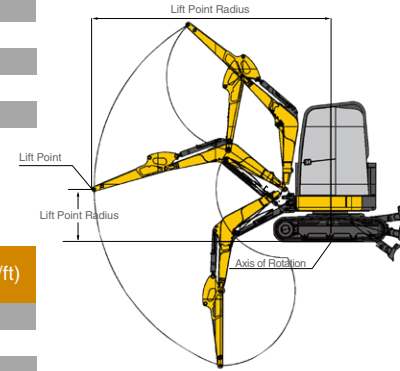

: Over front  
 : Over side or 360°

- 1.The lifting capacity is based on the ISO10567 standard.
- 2.\* = The maximum lifting capacity is limited by the hydraulic capacity of the machine.
- 3.The lifting capacity does not exceed 87% of the hydraulic capacity or 75% of the tipping load with the machine on level and firm ground.
- 4.The operator should be familiar with the machines operating- and maintenance manual.Local regulations concerning the safe operation of machinery must be followed at all times.
- 5.The lift diagrams only covers machines that are originally built by XCMG: without lifting chains and any other lifting equipment.
- 6.When the excavator is used to lift or handle materials, it must comply with local.





# Technical Specifications

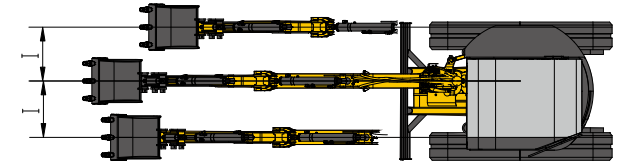
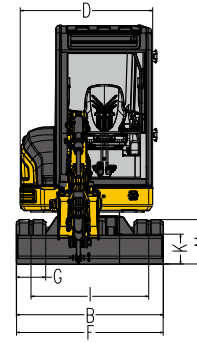
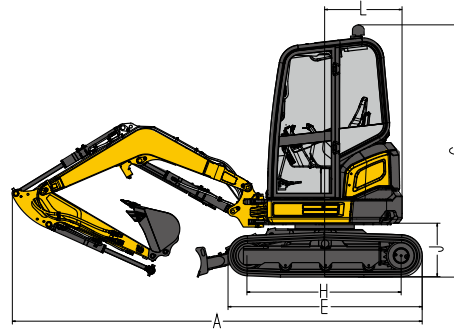
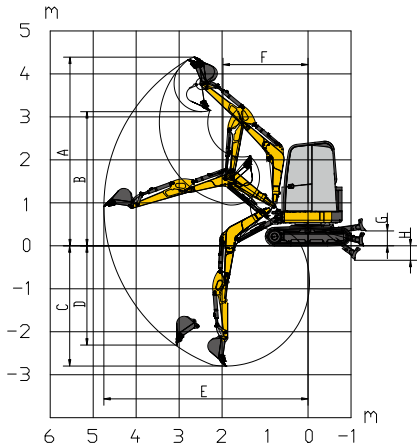

## Working range

### XE27U

A	Maximum digging height	4 390 mm (14'5")
B	Maximum dumping height	3 120 mm (10'3")
C	Maximum digging depth	2 800 mm (9'2")
D	Maximum vertical wall digging depth	2 310 mm (7'7")
E	Maximum digging radius	4 750 mm (15'7")
F	Minimum swing radius	1 980 mm (6'6")
G	Maximum Dozer Lifting Height	300 mm (12")
H	Maximum Dozer Cutting Depth	330 mm (13")
I	Boom deflection distance(left/right)	610/585 mm (24"/23")

## Dimensions

### XE27U

A	Overall length	4 190 mm (13'9")
B	Overall width	1 500 mm (4'11")
C	Overall height	2 580 mm (8'6")
D	Width of platform	1 350 mm (4'5")
E	Length of crawler	1 980 mm (6'6")
F	Width of chassis	1 500 mm (4'11")
G	Width of crawler	300 mm (12")
H	Distance between tumblers	1 560 mm (5'1")
I	Track gauge	1 200 mm (3'11")
J	Counterweight clearance	535 mm (21")
K	Minimum ground clearance	290 mm (11")
L	Minimum tail swing radius	790 mm (31")
M	Track height	457 mm (18")

## > Standard and Optional Equipment

### Engine

Air cleaner with clogging indicator	●
Air cleaner with double filter element	●
Collecting cylinder engine oil filter	●
Collecting cylinder main fuel filter	●
Radiator auxiliary water tank	●
Fuel-water separator	●
Alternator	●

### Hydraulic system

Control valve with LS relief valve	●
Pilot filter	●
Oil suction filter	●
Accumulator	●
Hydraulic oil ISO VG 46	●
Hydraulic oil ISO VG 32	○
Hydraulic oil ISO VG 68	○
Two-way piping	●
One-way/two-way piping	●
Quick coupler piping	●

### Cab & interior

AM-FM radio with bluetooth(Cab)	●
DAB bluetooth digital radio(Cab)	○
All-weather soundproof steel structure cab	●
Cup holder	●
Double stereo speaker(Cab)	●
Engine key switch	●
Emergency hammer	●
Fire extinguisher bracket	●
Washable floor mat	●
Footrest	●
Mechanical suspension seat	●
Openable upper front windshield(Cab)	●
Removable front lower windshield(Cab)	●
Tempered glass slide window(Cab)	●
Intermittent windshield wiper(Cab)	●
Retractable safety belt	●
Electric proportional joystick on left and right	●
Travel pedals with detachable manual control lever	●
Coat hook	●
High and low travel speed switch	●
Air conditioner(Cab)	●
Emergency power supply	●
Interior light(Cab)	●
Rearview mirror	●
Color LCD display	●

### Undercarriage

Track tensioning mechanism	●
Tow ring on the bottom frame	●
Bottom sealing plate of undercarriage	●
Sealing plate of travel motor	●
One track guards for each side (with steel track)	○
Dozer	●
300 mm(12")rubber track with 2x80 joints	●
300 mm(12")steel track	○
One carrier roller and three bottom rollers for each side	●

### Boom, arm and bucket

Boom-2.09 m(6'10")	●
Arm-1.3 m(4'3")	●
0.06 m³(0.078 yd³)/458 mm(1'6") bucket	●
Quick coupler	○
Thumb	○
Breaking Hammer	○
Scarifier	○

### Electrical system

Battery(1 x60 AH)	●
12 V cigarette lighter	○
12 V electric power port	●
Engine cooling water temperature display	●
Fuel level display	●
Engine speed display	●
Working hour meter	●
Warning of engine oil pressure and overheat	●
Charge indicator	●
Air filter blockage warning	●
Engine preheat indicator	●
Two front working light on the cab(LED)	●
Two rear working light on the cab(LED)	○
One working lights on the boom(LED)	●
Rotating beacon	●

### Conterweight

0.35 t(772 lb)counterweight	●
-----------------------------	---

### Lubrication system

Centralized lubricating system of slewing bearing,slewing motor and angle boom cylinder	●
Self-lubricating bearings for boom,arm and bucket	●

### Safety and guards

Lock for the cab door and each cabin	●
Warning horn	●
The quick coupler button with warning	●
Protective box for wiper motor	●
Travel parking brake	●
Swing parking brake	●
Battery disconnect switch	●
Dozer blade holding valve	●
Anti-burst valve on the boom	●
Anti-burst valve on the arm	●
Anti-burst valve guard	●
Hydraulic safety locking lever	●
Emergency escape hammer	●
Left and right rearview mirrors	●
Front guard net	○
Cab with std TOPS/ROPS and opt OPG when mounted front guard net	○
Canopy with TOPS/ROPS/OPG	●

Standard: ●

Optional: ○

· Some of these standard or optional equipment may not be available for certain markets.

· Pictures may include attachments and optional equipment that are not available in your area. · Materials and specifications are subjected to change without advance notice.

· Please contact your local XCMG dealer for more information on availability or to customise your machine to suit your applications requirements.

# Optimum Services , XCMG Guaranteed



XCMG approved attachments



Genuine parts



Financial solutions



Maintenance contract



Telematics



## Professional Integrated Complete Solutions

XCMG group has built a strong reputation based on the quality, reliability and durability of its construction machinery. What's more, XCMG has gradually established a service network to constantly provide its local integrated and highly efficient complete solutions for all customers.

## Full Range of Services Ready for you

In order to respond to your needs as fast as possible, XCMG experts are on their way to your job site from one of our facilities near you. Full range of services are available in order to reduce your total cost of ownership and increase your revenue.

## XCMG Global Spare parts System

Number	Material Number	Name	Quantity	Unit
1	88000000	CONTROL BOX ELECTRICAL	1	PC
2	88000000	CONTROL BOX ELECTRICAL	1	PC

Number	Material Number	Name	Quantity	Unit
1	88000000	CONTROL BOX ELECTRICAL	1	PC
2	88000000	CONTROL BOX ELECTRICAL	1	PC
3	88000000	CONTROL BOX ELECTRICAL	1	PC
4	88000000	CONTROL BOX ELECTRICAL	1	PC
5	88000000	CONTROL BOX ELECTRICAL	1	PC
6	88000000	CONTROL BOX ELECTRICAL	1	PC
7	88000000	CONTROL BOX ELECTRICAL	1	PC
8	88000000	CONTROL BOX ELECTRICAL	1	PC
9	88000000	CONTROL BOX ELECTRICAL	1	PC
10	88000000	CONTROL BOX ELECTRICAL	1	PC

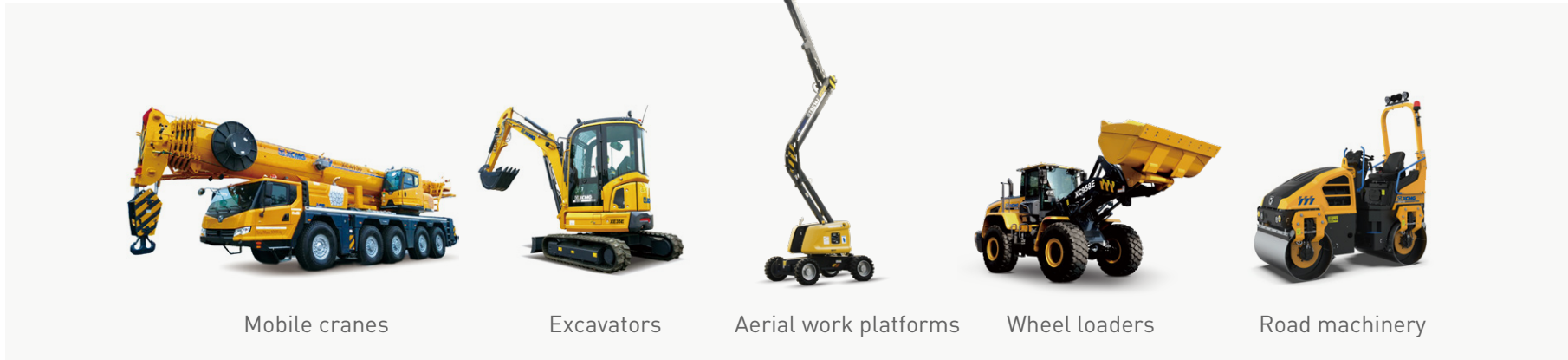

Mobile cranes

Excavators

Aerial work platforms

Wheel loaders

Road machinery



# XCMG

XCMG FOR YOUR SUCCESS

